

Colector Solar CS

Fisa tehnica

Descriere generala



- Colector solar presurizat cu tuburi vidate echipate cu heat-pipe
- Utilizabil pe toata perioada anului, poate fi instalat in aplicatii de preparare a apei calde menajere, aport la incalzire, incalzirea piscinelor sau in aplicatii industriale complexe.
- Tehnologia tuburilor vidate cu heat pipe asigura o productie eficienta si sigura de energie termica, intr-un sistem usor de instalat si cu costuri mici de intretinere. Fiecare tub functioneaza independent iar deteriorarea unui tub nu determina nefunctionarea sistemului solar ci doar reducerea capacitatii de absorbtie si incalzire.

Caracteristici principale



- Performanta buna chiar si la temperaturi scazute
- Rezistenta la grindina pana la 30 mm si la vant de pana la 100 km/h
- Tuburile sunt usor de inlocuit, fara sa fie necesara golirea sistemului
- Heat pipe-uri cu condensator de 22 mm si rezistente la temperaturi de pana la -35 °C
- Echipat cu teaca pentru senzor de temperatura pe ambele iesiri
- Suporti de inclinare disponibili pentru unghiuri cuprinse intre 10 - 65°
- Presiune maxima de lucru – 8 bar
- Racorduri filetate 3/4" M
- Temperatura de stangare in tuburi / colector : 280 °C / 190 °C
- **Garantie 10 ani**
- Fabricat in Romania 

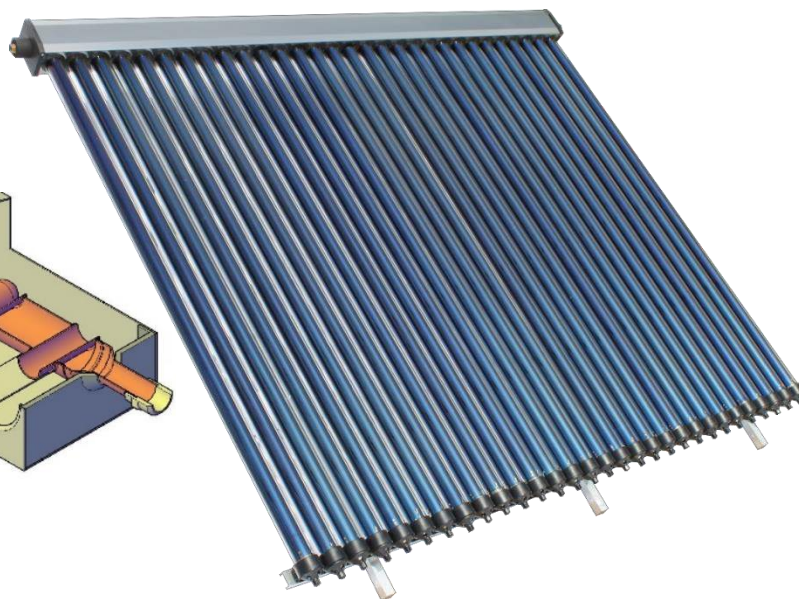
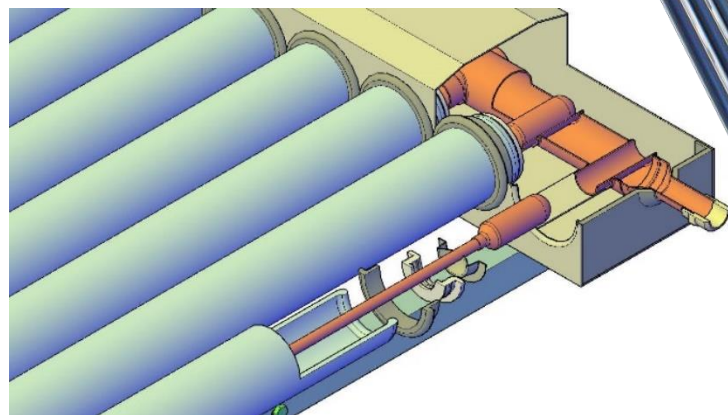

Specificatii constructive

Schimbator de caldura :	cupru \varnothing 42mm
Carcasa exterioara :	inox AISI 430, protejat in folie
Izolatie termica :	spuma poliuretana rigida cu grosime de 30 mm peste cochilie vata minerala 20 mm
Tuburi vidate :	sticla borosilicata, 58x1800 mm, grosime 1.8 mm
Straturi de absorbtie tub :	Cu/SS-ALN(H)/SS-ALN(L)/ALN
Heat-pipe :	Cupru / aluminiu de inalta puritate cu condensator de 22mm
Componente fixare :	PVC cu protectie pentru raze UV
Componente etansare :	cauciuc siliconic
Cadru fixare :	profil aluminiu 30x30x30x2 mm

Specificatii tehnice si performanta

	CS 10	CS 12	CS 15	CS 20	CS 25	CS 30
Tuburi vidate cu heat-pipe	10	12	15	20	25	30
Suprafata absorbtie	0.99 mp	1.18 mp	1.48 mp	1.98 mp	2.46 mp	2.97 mp
Suprafata bruta	1.60 mp	2.00 mp	2.58 mp	3.34 mp	4.00 mp	4.8 mp
Greutate (gol)	33 kg	38 kg	47 kg	62 kg	78 kg	92 kg
Dimensiuni panou	200 x 80 x 18 cm	200 x 100 x 18 cm	200 x 129 x 18 cm	200 x 167 x 18 cm	200 x 200 x 18 cm	200 x 240 x 18 cm
Volum schimbator caldura	0.8 l	1.0 l	1.2 l	1.6 l	2.0	2.4 l
Debit ideal	1 l/min	1.2 l/min	1.5 l/min	2.0 l/min	2.5 l/min	3.0 l/min
Putere maxima ($\vartheta_m - \vartheta_a=0$ K)	680 W	816 W	1020 W	1360 W	1700 W	2040 W
Capacitate anuala pe metru patrat	385 KW (Bucuresti - 1350 kw/mp radiatie solara, $\vartheta_m=50^\circ\text{C}$.)					
Indicatori performanta	$\eta_0 = 0,726$ $a_1 = 1,668 \text{ W}/(\text{m}^2\text{K})$ $a_2 = 0,017 \text{ W}/(\text{m}^2\text{K})$					